

Service Manual

Portable Stereo CD System

Radio Cassette

*1  DOLBY SYSTEM

*2 **MASH**
multi-stage noise shaping

COMPACT
disc
DIGITAL AUDIO

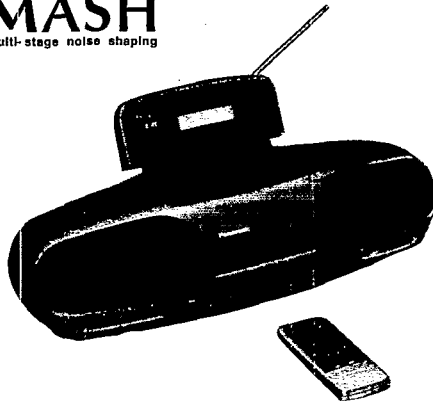

RX-DT707

Colour

(K) Black Type

Areas

Suffix for Model No.	Area	Colour
(EB)	Great Britain	(K)
(EG)	Europe and Germany	

TAPE DECK: RX-FD55 MECHANISM SERIES (AR300)

TRAVERSE DECK: SL-CH550 MECHANISM SERIES (RAE0111Z)

■ SPECIFICATIONS

General:

Power Requirement: AC; 230~240 V, 50 Hz
 Battery; 15 V (10 R20/LR20, UM-1 batteries)
 Memory Back-up for Computer/Clock;
 6 V (4 R6/LR6, UM-3 batteries)

Power Consumption: 57 W

Power Output: Low ch; 11.6 W×2 (PMPO)
 High ch; 4.2 W×2 (PMPO)

Speaker: Woofer; 10 cm PM Dynamic speaker
 2.7Ω

Squawker Tweeter; 8 cm PM Dynamic speaker 8Ω

Inputs: MIX MIC; 2.5 mV, 200~600Ω, Ø3.5
 AUX; 200 mV, 47 kΩ

Outputs: HEADPHONES; 32Ω, Ø3.5
 CD OUT; 1 V (CD 0 dB)

Dimensions: 710 (W)×205 (H)×263 (D) mm
 (When the top panel is open)
 8.0 kg without batteries

Weight:

Disc Player Section:

Sampling Frequency: 44.1 kHz

Decoding: 16-bit linear

Beam Source: Semiconductor laser
 (wavelength 780 nm)

No. of Channels: 2 channels, stereo

Frequency Response: 20~20,000 Hz (+1, -2 dB)

Wow and Flutter: Unmeasurable

D/A Converter: MASH (1 BIT DAC)

Radio Section:

Frequency Range: FM; 87.5~108 MHz

LW; 144~288 kHz

MW; 522~1611 kHz

Intermediate Frequency: FM; 10.7 MHz

AM (LW/MW); 459 kHz

FM; 5 μV/0.1 mW output
 (-3 dB Limit Sens.)

LW; 100 μV/m/0.1 mW output (Max.)

MW; 56.3 μV/m/0.1 mW output (Max.)

Tape Deck Section:

Frequency Range: 30~16,000 Hz (with normal tape)

30~17,000 Hz (with CrO₂ tape)

30~18,000 Hz (with METAL tape)

Recording System: AC bias, AC erase (Deck 2)

Tape Speed: 4.8 cm/sec.

Monitor System: Variable sound monitor

Track System: 4-track 2-channel stereo recording and playback

*1 **Dolby noise reduction manufactured under license from Dolby Laboratories Licensing Corporation.**

"Dolby" and the double-D symbol are trade marks of Dolby Laboratories Licensing Corporation.

*2 **Technics (or Panasonic) developed the world's first MASH type DAC and ADC. MASH technology was invented by NTT (LSI Labs).**

MASH is a trademark of NTT.

Notes:

- Weights and dimensions shown are approximate.
- Design and specifications are subject to change without notice.

Panasonic

■ CONTENTS

	Page		Page
• PRECAUTION OF LASER DIODE	2	• NEW DIGITAL SERVO CIRCUIT	53
• LOCATION OF CONTROLS	3~5	• SELF DIAGNOSTIC FUNCTION	54
• TIME ADJUSTING	6	• TROUBLESHOOTING GUIDE	55~56
• DISASSEMBLY INSTRUCTION	7~18	• FUNCTION OF IC TERMINALS	57~61
• SCHEMATIC DIAGRAM	19~34	• BLOCK DIAGRAM	62~68
• PRINTED CIRCUIT BOARD DIAGRAM	35~41	• REPLACEMENT PARTS LIST	69~78, 85, 86
• WIRING CONNECTION DIAGRAM	42, 43	• PACKAGING	72
• PREPARATIONS FOR CHECK AND ADJUSTMENT OF P.C.B.	44~48	• CABINET PARTS LOCATION	79, 80
• MEASUREMENTS AND ADJUSTMENTS	49~52	• MECHANISM PARTS LOCATION	81~84
		• LOADING UNIT PARTS LOCATION	87

■ PRECAUTION OF LASER DIODE

CAUTION: This product utilizes a laser diode with the unit turned "on", invisible laser radiation is emitted from the pick up lens.
Wave length: 780 nm
Maximum output radiation power from pick up: 100 μ W/VDE

Laser radiation from the pick up unit is safety level, but be sure the followings:

1. Do not disassemble the optical pick up unit, since radiation from exposed laser diode is dangerous.
2. Do not adjust the variable resistor on the pickup unit. It was already adjusted.
3. Do not look at the focus lens using optical instruments.
4. Recommend not to look at pick up lens for a long time.

ACHTUNG: Dieses produkt enthält eine laserdioden. Im eingeschalteten zustand wird unsichtbare laserstrahlung von der lasereinheit abgestrahlt.

Wellenlänge: 780 nm
Maximale strahlungsleistung der lasereinheit: 100 μ W/VDE

Die strahlung an der lasereinheit ist ungefährlich, wenn folgende punkte beachtet werden:

1. Die lasereinheit nicht zerlegen, da die strahlung an der freigelegten laserdioden gefährlich ist.
2. Den werksseitig justierten einstellregler der lasereinheit nicht verstellen.
3. Nicht mit optischen instrumenten in die fokussierlinse blicken.
4. Nicht über längere zeit in die fokussierlinse blicken.

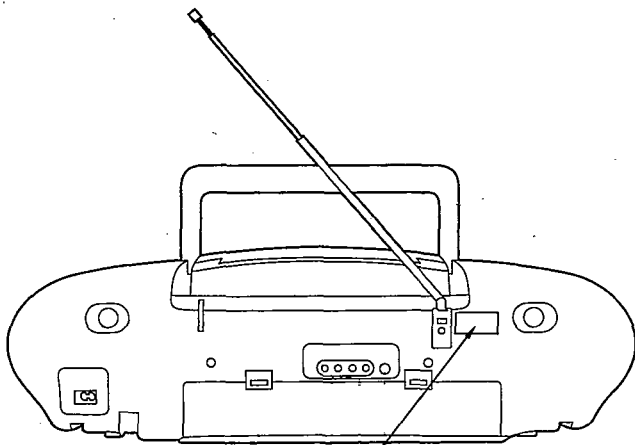

**CLASS 1
LASER PRODUCT**

**LUOKAN 1 LASERLAITE
KLASS 1 LASER APPARAT**

**ADVARSEL: USYNTLIG LASERSTRÅLING
VED ÅBNING, NÅR SIKKERHEDSAF-
BRYDERE ER UDE AF FUNKTION.
UNDGÅ UDSÆTTELSE FOR STRÅLING.**

**VARO! Avattaessa ja
suojalkitus ohitettaessa
olet alttiina näkymätön
lasersäteilylle.
Älä katso säteeseen.**

**VARNING! Osynlig
laserstråling när denna
del är öppnad och
spårren är urkopplad.
Betrakta ej strålen.**

**VORSICHT- Unsichtbare
Laserstrahlung, wenn
Abdeckung geöffnet.
Nicht dem Strahl
aussetzen.**

**DANGER- Invisible
laser radiation when
open.
AVOID DIRECT EX-
POSURE TO BEAM.**

**ADVERSEL! Usynlig
laserstråling når deksel
åpnes og sikkerheds-lås
brytes. Unngå
eksponering for strålen.**

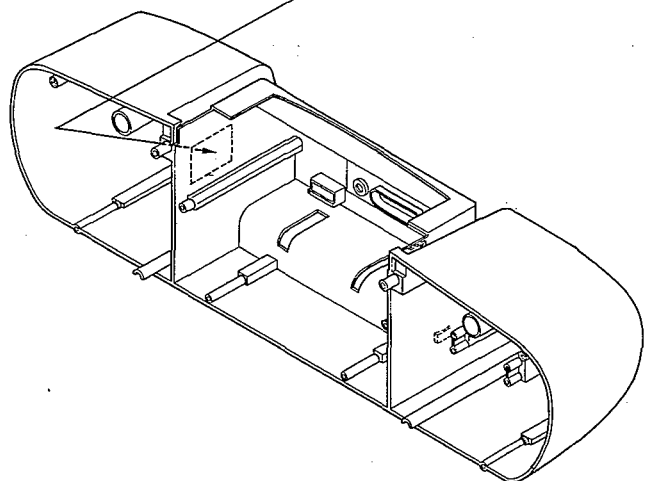

LOCATION OF CONTROLS

The functions indicated by the numbers with black back ground (for example ③) can also be activated from the remote control transmitter. (See page 5.)

CD/GENERAL CONTROLS

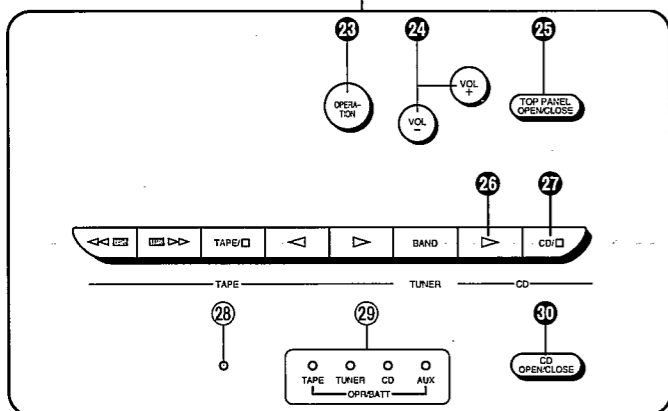
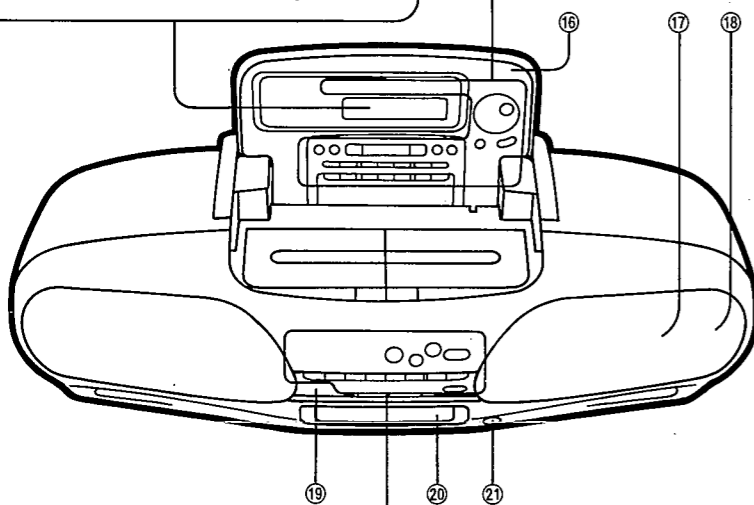
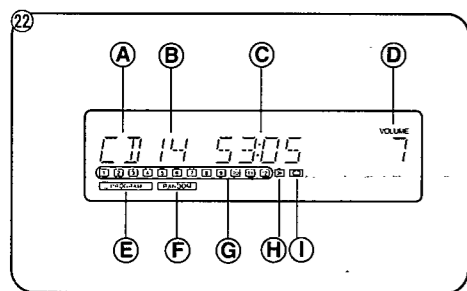
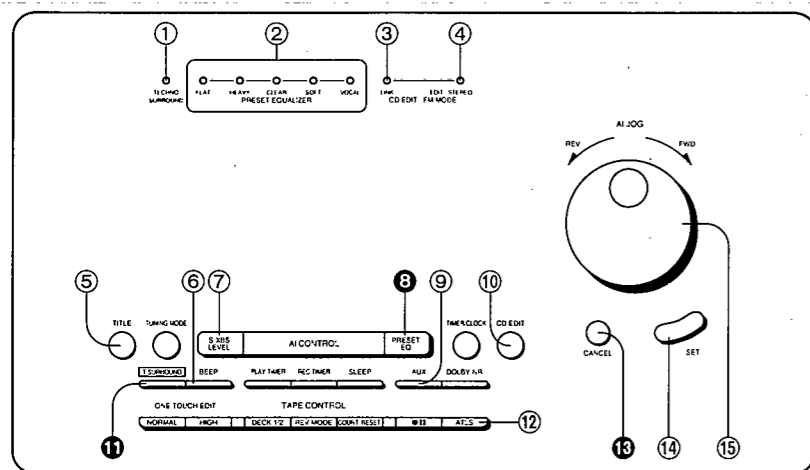

- ① Surround indicator (TECHNO SURROUND)
- ② Preset equalizer mode indicator (PRESET EQUALIZER)
- ③ Link edit indicator (LINK)
- ④ CD edit/stereo indicator (EDIT/STEREO)
- ⑤ Title button (TITLE)
- ⑥ Beep sound button (BEEP)
The beep sound (beep) will be emitted each time the operation button is pressed. The beep function can be turned on and off by pressing this button.
- ⑦ Super extra bass system button (S-XBS LEVEL)
- ⑧ Preset equalizer button (PRESET EQ)
- ⑨ Aux button (AUX)
- ⑩ Compact disc edit button (CD EDIT)
Press this button to select the desired edit mode.
- ⑪ Surround function button (T-SURROUND)
- ⑫ Automatic tape level setting button (ATLS)
Press this button to begin the recording from a CD.
- ⑬ Cancel button (CANCEL)
- ⑭ SET button (SET)
- ⑮ Jog dial (AI JOG)
- ⑯ Top panel
- ⑰ Speakers [Woofer] (10 cm, 2.7Ω)
- ⑱ Speakers [Squawker Tweeter] (8 cm, 8Ω)
- ⑲ Remote control sensor
- ⑳ Disc tray
- ㉑ Headphones jack (PHONES) (∅3.5, 32Ω)
- ㉒ Display section
 - A: CD mode indicator
 - B: Track display
 - C: Playing time display
 - D: Volume level display (VOLUME)
 - E: Program indicator (PROGRAM)
 - F: Random indicator (RANDOM)
 - G: Music matrix
 - H: Over mark indicator (▶)
 - I: Repeat indicator (◀)
- ㉓ Operation switch (OPERATION, OFF/ON)
- ㉔ Volume control (VOL.)
- ㉕ Top panel open/close button (TOP PANEL OPEN/CLOSE)
- ㉖ Play button (▶)
Press this button to start the disc play.
- ㉗ CD mode/stop button (CD/□)
Press this button to listen to the CD or to stop the CD playing.
- ㉘ AC connection indicator
While the AC mains supply is used, it lights as an AC connection indicator.
- ㉙ Play mode/operation/battery check indicators
It functions as a battery check indicator when the unit is operated on batteries.
- ㉚ CD open/close button (CD OPEN/CLOSE)

TUNER CONTROLS

- ⑳ Tuning mode button (TUNING MODE)
- ㉑ Tuner/band button (TUNER, BAND)
Press this button to select the desired radio band.
- ㉒ Display section
 - A: Band indicator (FM/MW/LW)
 - B: Frequency display
 - C: Channel number indicators
 - D: Program indicator (PROGRAM)
 - E: Tuning indicator (TUNED)
 - F: Stereo indicator (STEREO)

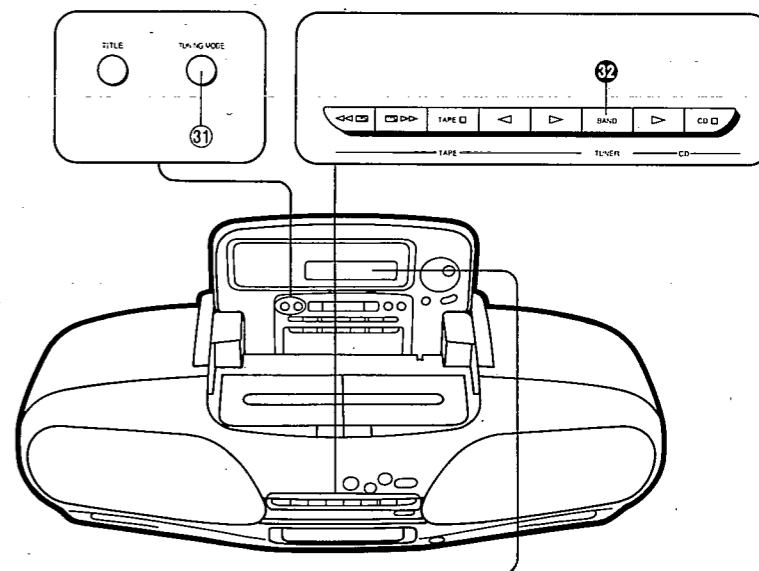
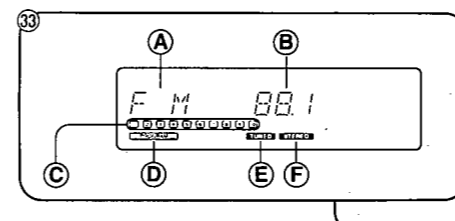

DECK CONTROLS

- ㉓ Edit recording buttons (ONE TOUCH EDIT)
Press one of these buttons to start the synchronized edit recording.
- ㉔ Deck 1/2 selector (DECK 1/2)
Press this button to select the operation deck (deck 1 or 2).
- ㉕ Reverse mode select button (REV MODE)
- ㉖ Counter reset button (COUNT RESET)
Press this button to reset the tape counter.
- ㉗ Rec-pause button (●||)
- ㉘ Dolby NR button (DOLBY NR)
- ㉙ Deck 1 cassette eject button (▲ EJECT)
- ㉚ Deck 1 cassette compartment cover
- ㉛ Deck 2 cassette compartment cover
- ㉜ Deck 2 cassette eject button (▲ EJECT)
- ㉝ Fast/tape program sensor buttons (◀◀ TPS ▶▶)
Press one of these buttons to fast forward or rewind the tape during stop condition, or to skip to the beginning of the next or present tune during playback.
- ㉞ Tape mode/stop button (TAPE/□)
Press this button to listen to tapes or to stop the tape.
- ㉟ Reverse-side playback button (◀)
Press this button to begin the playback (or recording) from the reverse side of the tape.
- ㊱ Forward-side playback button (▶)
Press this button to begin the playback (or recording) from the forward side of the tape.
- ㊲ Display section
 - A: Tape mode indicator (TAPE)
 - B: Tape counter
 - C: Running indicator
 - D: Deck 1/2 indicators (DECK 1 DECK 2)
 - E: Reverse mode indicator (◀)
 - F: Dolby NR indicator (DOLBY NR)
 - G: Recording indicator (REC)
 - H: Tape direction indicators (◀◀ ▶▶)

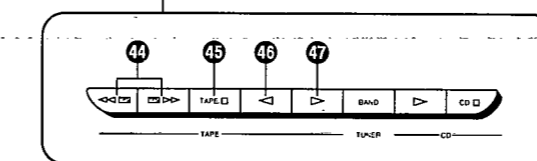
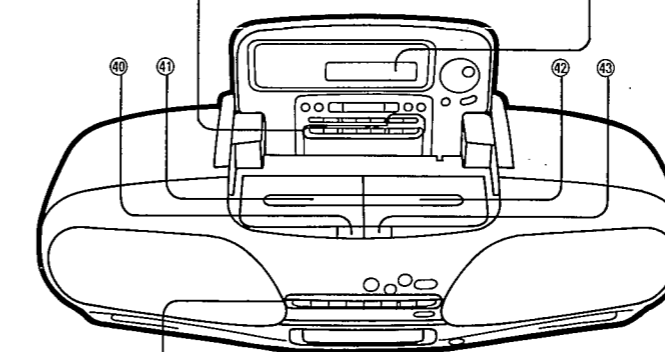
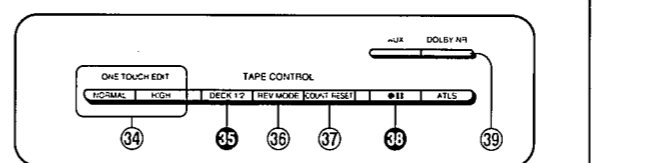
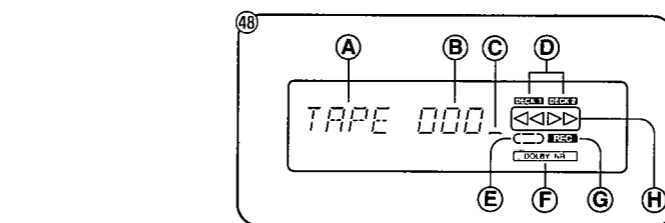

●TIMER CONTROLS

- ④9 **Timer play button (PLAY-TIMER)**
Press this button for timer play.
- ⑤0 **Timer recording button (REC-TIMER)**
Press this button for timer recording.
- ⑤1 **Sleep button (SLEEP)**
Press this button when you wish to fall asleep while listening to music.
- ⑤2 **Timer clock button (TIMER/CLOCK)**
- ⑤3 **Display section**
A: Timer ON indicator (ON)
B: Timer play indicator (TIMER)
C: Timer recording indicator (TIMER-REC)
D: Timer OFF indicator (OFF)
E: Sleep timer indicator (SLEEP)
F: Time display

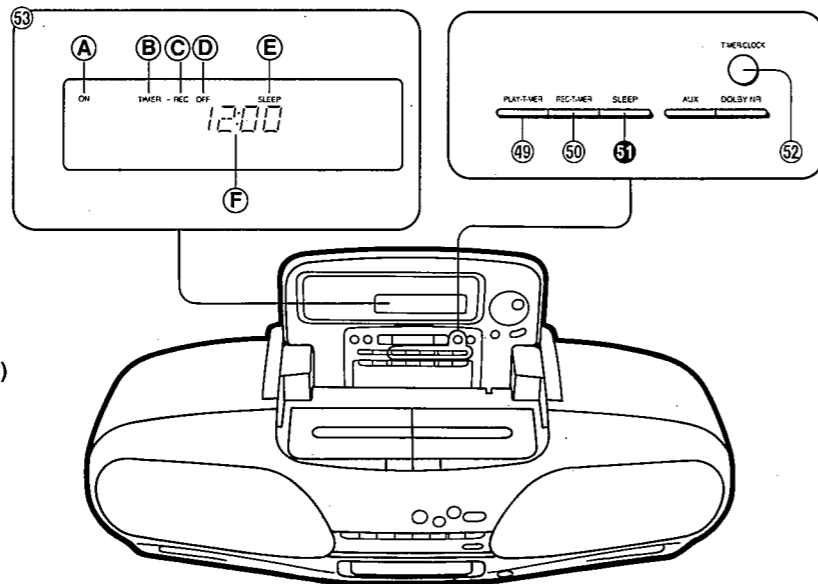

●REAR PANEL SECTION

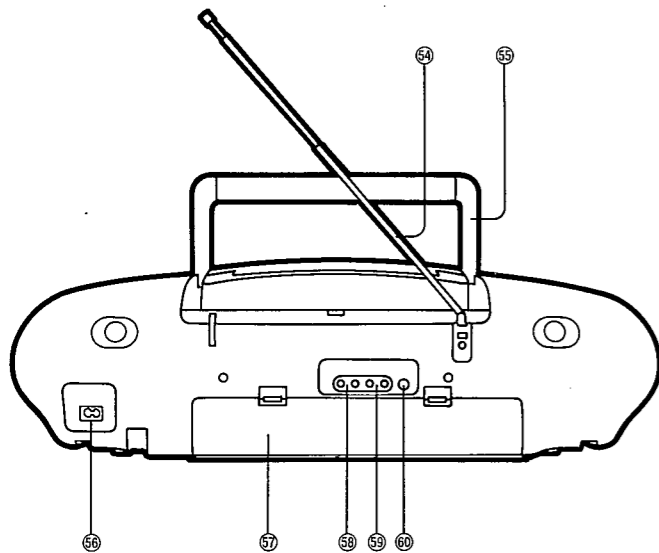

- ⑤4 Telescopic antenna
- ⑤5 Handle
- ⑤6 AC socket (AC IN~)
- ⑤7 Battery compartment cover
- ⑤8 Aux input jacks (AUX IN) (200 mV, 4.7 kΩ)
- ⑤9 CD output jacks (CD OUT) (1 V, CD 0 dB)
- ⑥0 Mixing microphone jack (MIX MIC)
(∅3.5, 200~600Ω)

- ⑥7 **Display button (DISPLAY)**
Press this button when you wish to confirm the present time while listening to CD, radio and tape.
- ⑥8 **Skip/search buttons (◀◀/▶▶, ▶▶/▶▶)**
Press one of these buttons to skip (backward or forward) the tracks, or to search (backward or forward) the desired portion of the disc.

●REMOTE CONTROL OPERATION

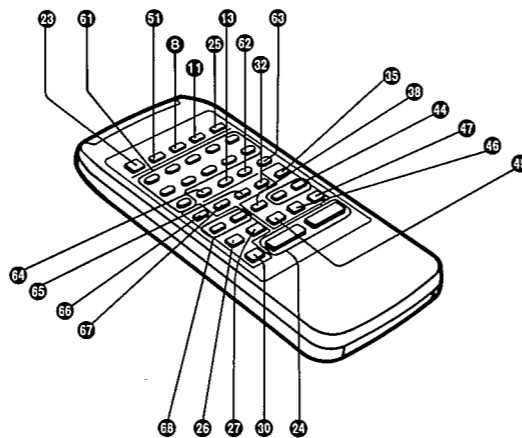

- ⑥1 **Numeric buttons (1-10/0, +10)**
These buttons are used to specify the CD's track (1-10, +10), and select the preset memory channel of the tuner (1-10).
- ⑥2 **Random button (RANDOM)**
Press this button to let the microcomputer make a random selection of the sequence.
- ⑥3 **Repeat button (REPEAT)**
Press this button to activate the repeat mode. The repeat indicator will appear.
- ⑥4 **Program button (PROGRAM)**
Press this button for CD program-play and for preset memory of the tuner.
- ⑥5 **FM mode/beat proof button (FM MODE/B.P)**
The functions of this button change according to the selected radio band.
MW/LW: Beat proof
(for recording from the MW/LW radio)
FM: MONO/STEREO
- ⑥6 **Pause button (||)**
Press this button to stop the disc temporarily.

■ TIME ADJUSTING

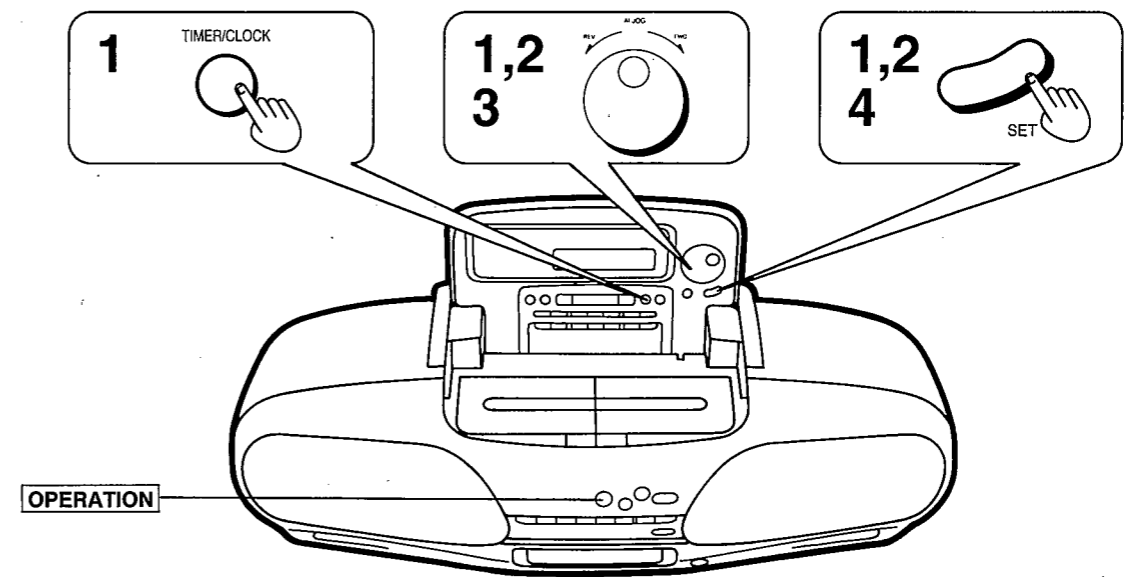

OPERATION

Before operation, press the operation switch to turn on the unit.

For example:
To set the time at 16:20.

- 1 Press the timer/clock button, and then turn the jog dial to select the "CLOCK" mode.
The display will change to "P-TIMER"-"R-TIMER"-"SLEEP"-"CLOCK".

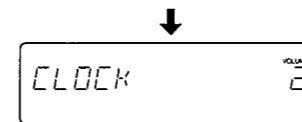
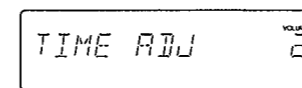

Press the SET button.

- 2 Turn the jog dial to adjust the correct hour display.
FWD: Increase.
REV: Decrease.

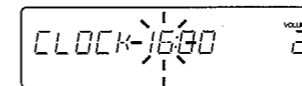

Flashing

Press the SET button.

- 3 Turn the jog dial to adjust the correct minute display.
Note that the minute "00" display appears following "59", but the hour display is not changed.

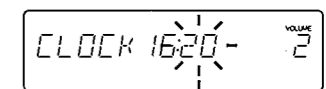

Flashing

- 4 Press the SET button to finish setting the time.
The display will change to the previous display.

When the SET button is pressed, the clock is reset to "0" second.
When a wrong operation occurs while operations of steps 1~3, press the cancel button, then the unit is returned to the previous mode.

HANDLING PRECAUTIONS FOR TRAVERSE DECK

The laser diode in the traverse deck (optical pickup) may break down due to potential difference caused by static electricity of clothes or human body.

So, be careful of electrostatic breakdown during repair of the traverse deck (optical pickup).

Handling of traverse deck (optical pickup)

1. Do not subject the traverse deck (optical pickup) to static electricity as it is extremely sensitive to electrical shock.
2. To prevent the breakdown of the laser diode, an anti-static shorting pin is inserted into the flexible board (FPC board). When removing or connecting the short pin, finish the job in as short time as possible.
3. Take care not to apply excessive stress to the flexible board (FPC board).
4. Do not turn the variable resistor (laser power adjustment). It has already been adjusted.

Grounding for electrostatic breakdown prevention

1. Human body grounding
Use the anti-static wrist strap to discharge the static electricity from your body.
2. Work table grounding
Put a conductive material (sheet) or steel sheet on the area where the traverse deck (optical pickup) is placed, and ground the sheet.

Caution:

The static electricity of your clothes will not be grounded through the wrist strap. So, take care not to let your clothes touch the traverse deck (optical pickup).

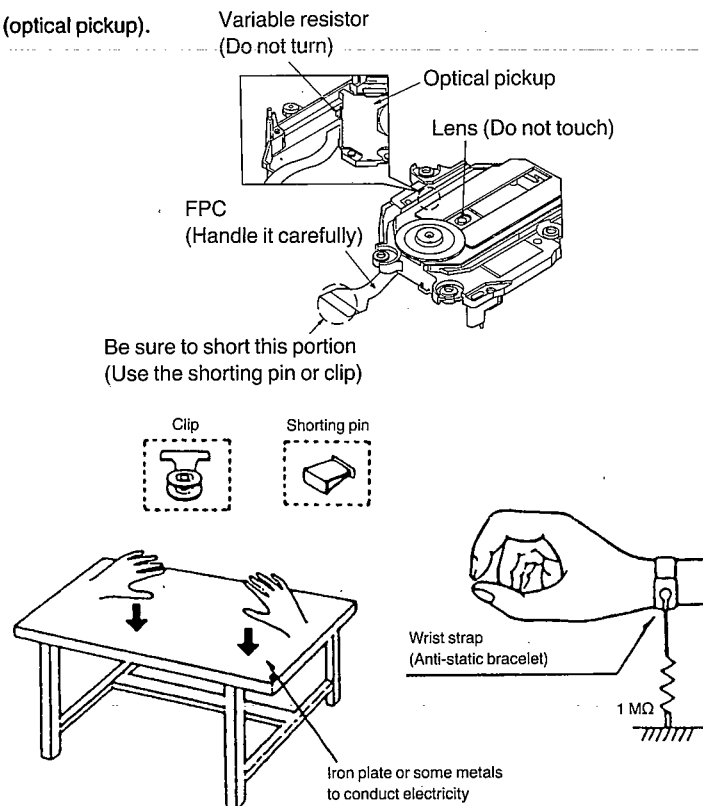

DISASSEMBLY INSTRUCTIONS

- Use a phillips screwdriver whose blade is 13 cm long and over to remove screws fixing the rear cabinet.

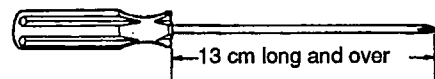

- Be sure to place the unit on soft cloth or similar material to prevent scratches when disassembling it.

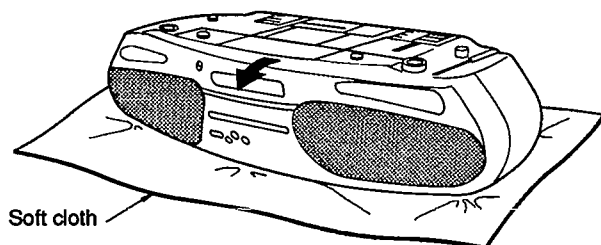

Ref. No. 2 Removal of the Front Cabinet

Procedure 1→2

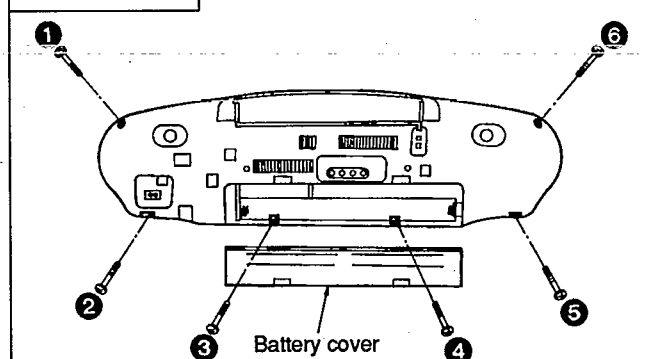

1. Remove the battery cover.
2. Remove 6 screws (1-6).

Notes:
1. Note that the two claws (shown in the right figure) hook the front cabinet when removing the front cabinet.
2. Be careful not to bend pins of the speaker output connector (CP605).

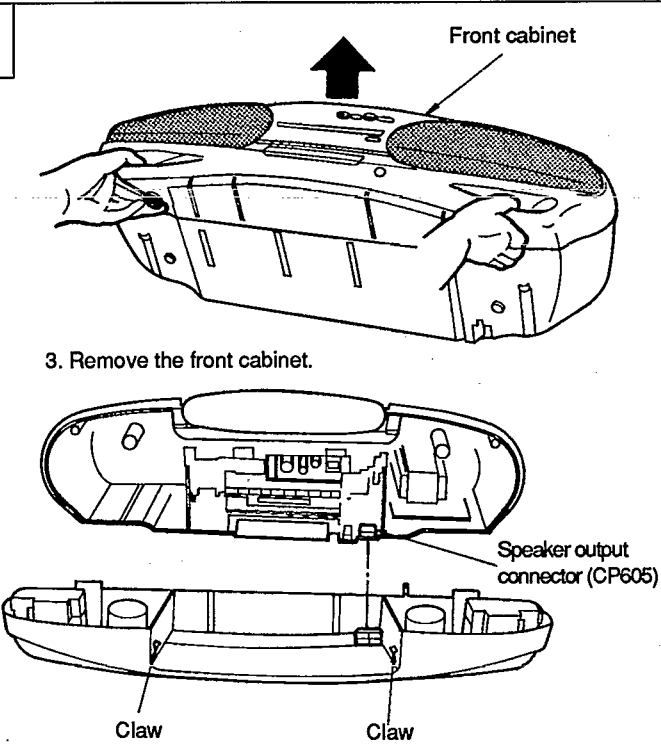

Ref. No. 3 Removal of the Operation P.C.B.

Procedure 1→2→3

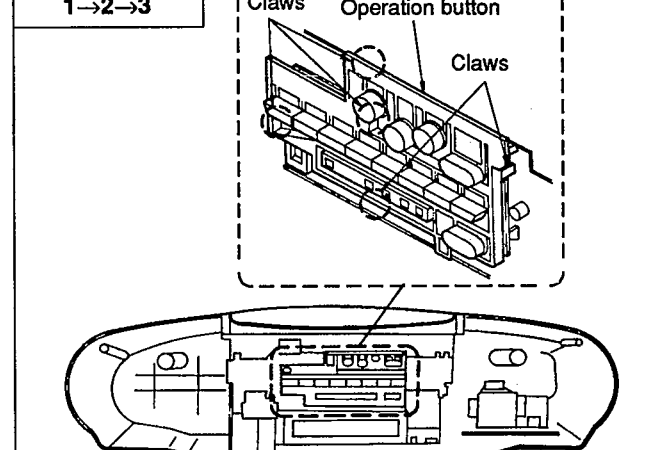

1. Release 5 claws.
2. Remove the operation button.

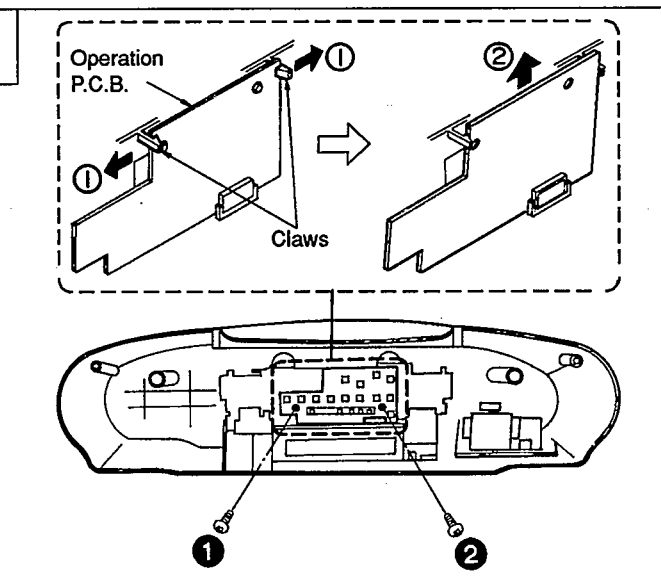

3. Remove 2 screws (1, 2).
4. Remove 2 claws in the direction of arrow 1.
5. Remove the operation P.C.B. in the direction of arrow 2.

Ref. No. 4 Removal of the Main Unit

Procedure 1→2→4

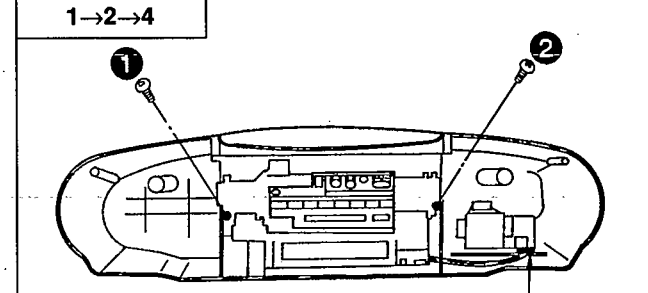

1. Release the connector (CP650).
2. Remove 2 screws (1, 2).

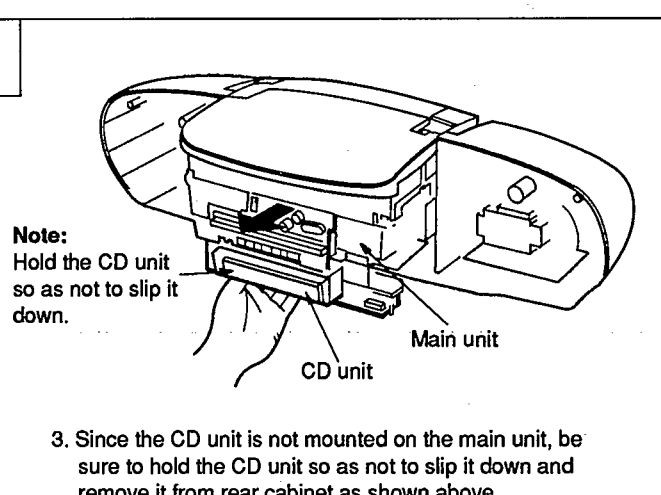

Note: Hold the CD unit so as not to slip it down and remove it from rear cabinet as shown above.

Ref. No. 1 Removal of the Handle

Procedure 1

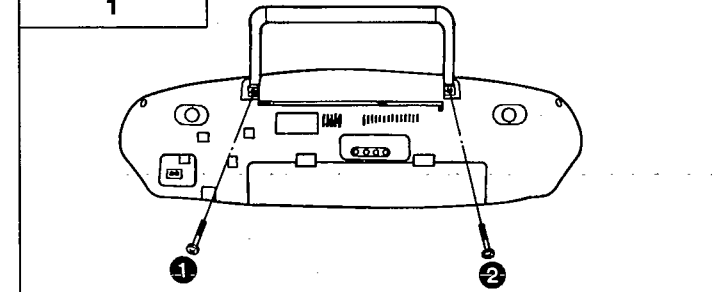

1. Remove 2 screws (1, 2).

Ref. No. 2 Removal of the Handle

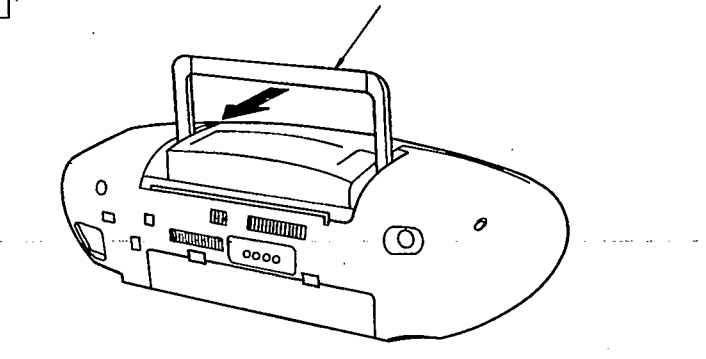

2. Slide out the handle in the direction of the arrow.

Ref. No. 5 Removal of the Cassette Panel

Procedure
1→2→5

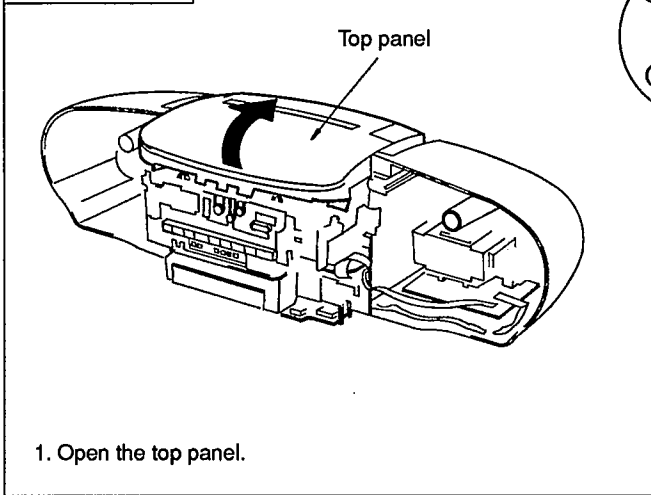

1. Open the top panel.

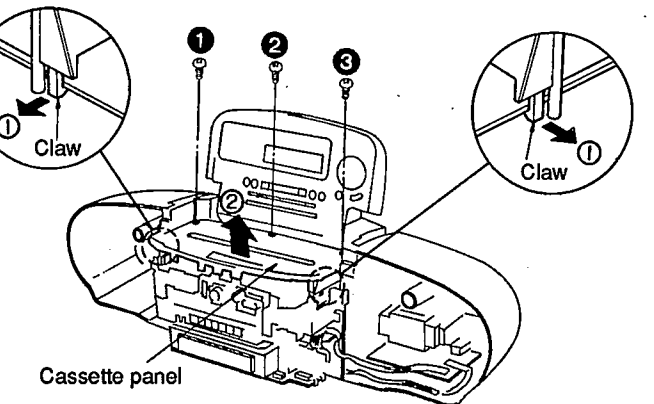

2. Remove 3 screws (1~3).
3. Release 2 claws in the direction of arrow ①.
4. Remove the cassette panel in the direction of arrow ②.

Ref. No. 6 Removal of the Mechanism Unit

Procedure
1→2→5→6

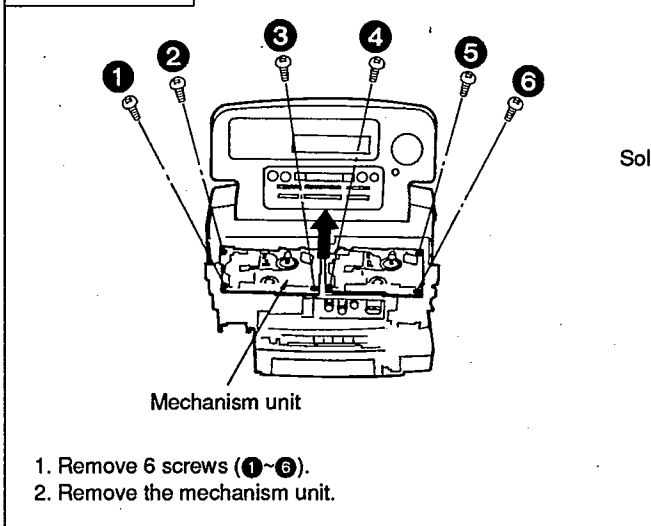

1. Remove 6 screws (1~6).
2. Remove the mechanism unit.

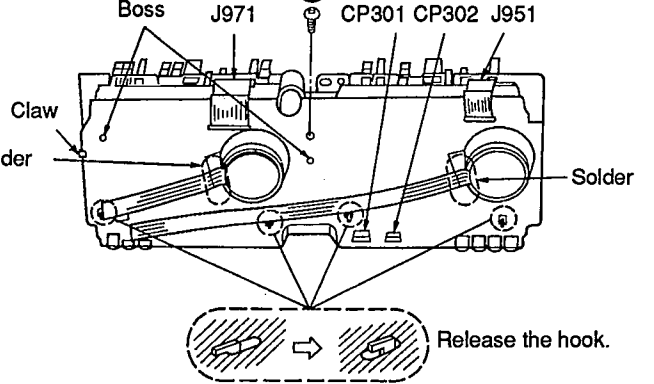

3. Release 4 connectors (J951, J971, CP301, CP302).
4. Resolder 2 solders.
5. Remove the screw (7).
6. Release the claw.
7. Release 2 bosses.
8. Release 4 hooks.

Ref. No. 7 Removal of the CD Unit

Procedure
1→2→4→7

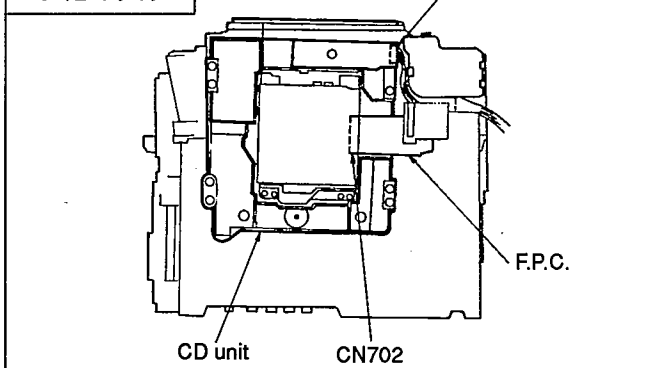

1. Release the connector (CP790).
2. Release the connector (CN702).
3. Remove the CD unit.

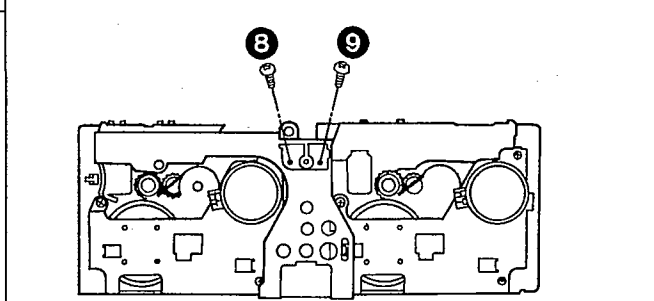

9. Remove 2 screws (8, 9).

Ref. No. 8 Removal of the Headphones P.C.B.

Procedure
1→2→4→8

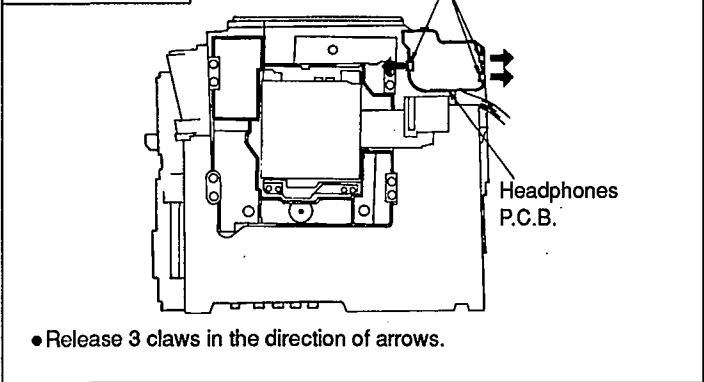

- Release 3 claws in the direction of arrows.

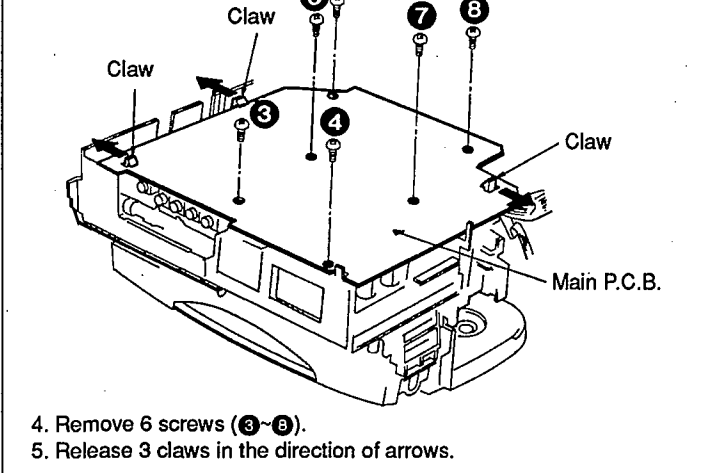

4. Remove 6 screws (3~8).
5. Release 3 claws in the direction of arrows.

Ref. No. 9 Removal of the Main P.C.B.

Procedure
1→2→4→5→
6→7→8→9

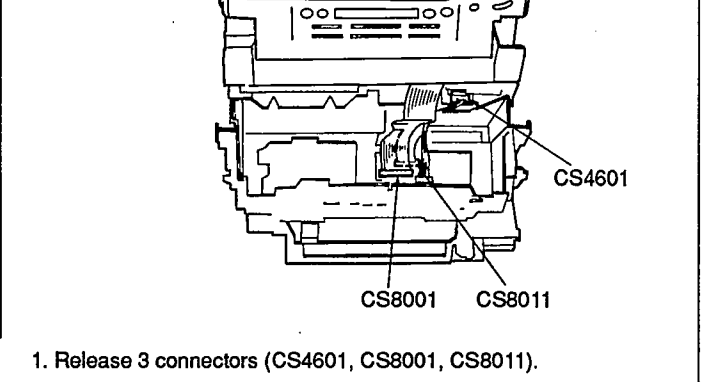

1. Release 3 connectors (CS4601, CS8001, CS8011).

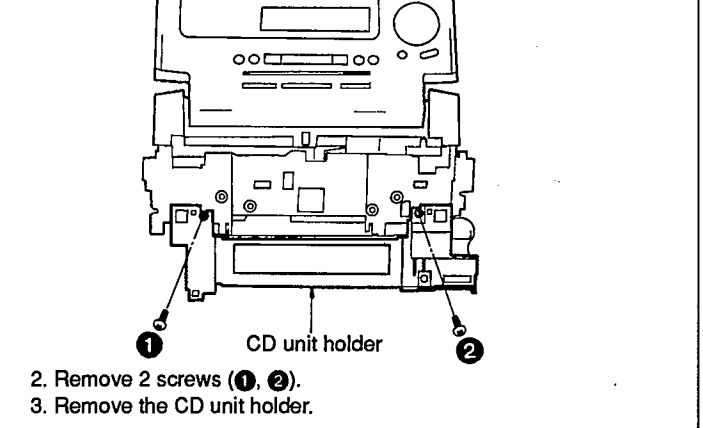

2. Remove 2 screws (1, 2).
3. Remove the CD unit holder.

Ref. No. 10 Removal of the Top Panel

Procedure
1→2→4→
5→6→10

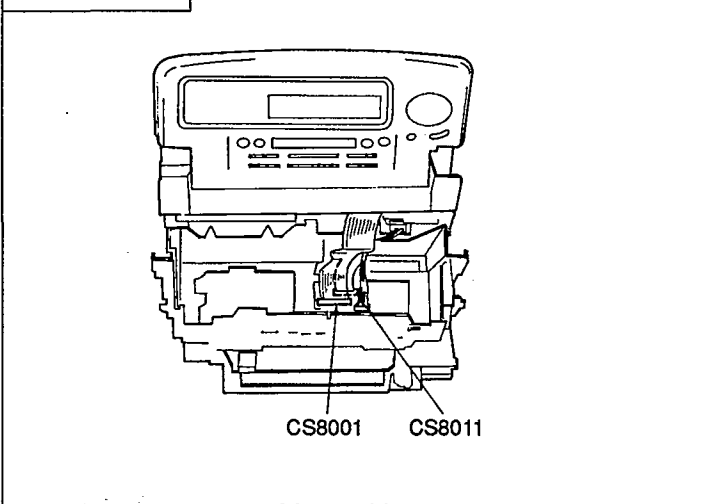

1. Release 2 connectors (CS8001, CS8011).
2. Remove 8 screws (1~8).
3. Remove the spring (A) and holder (A).
4. Remove the top panel in the direction of arrow.
5. Remove the spring (B).
6. Remove the holder (B).
7. Remove the lock lever.

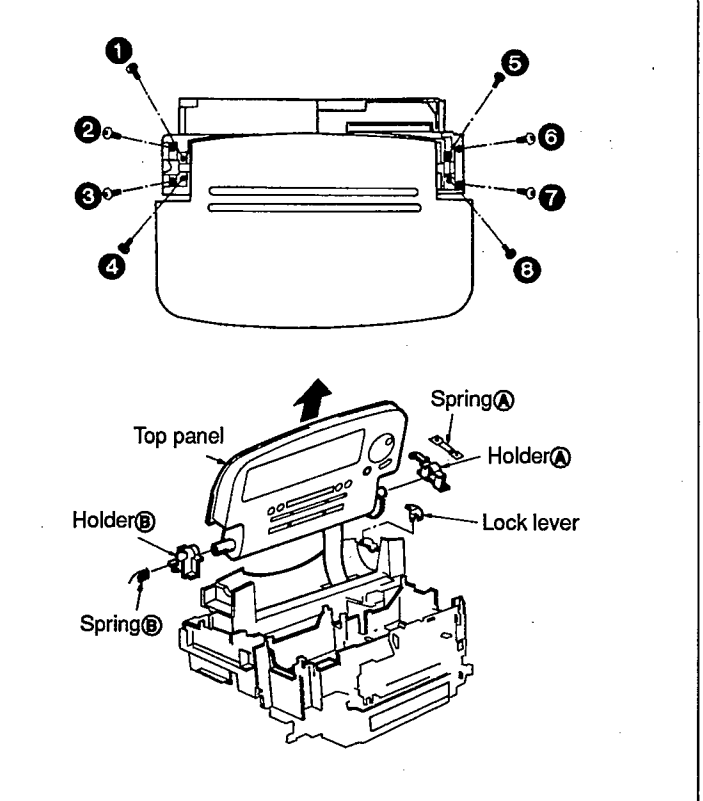

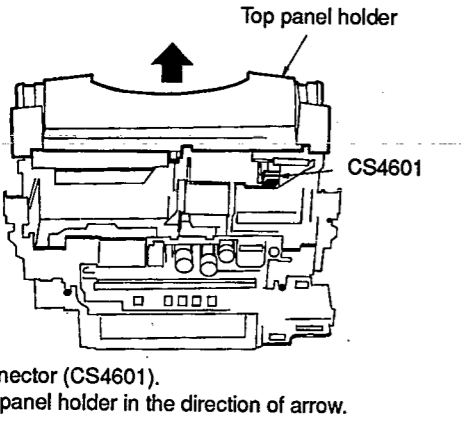
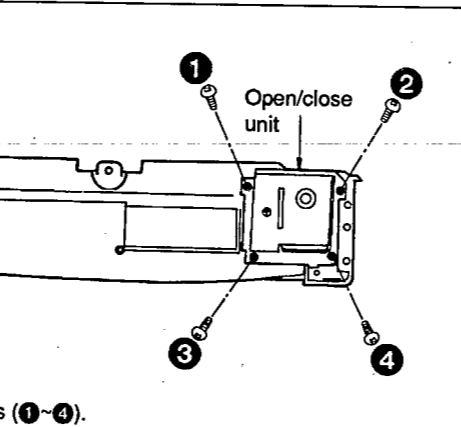
<p>Ref. No. 11</p>	<p>Removal of the Top Panel Holder</p>	<p>Ref. No. 12</p>	<p>Removal of the Open/Close Unit</p>
<p>Procedure 1→2→4→5→6→10→11</p>		<p>Procedure 1→2→4→5→6→10→11→12</p>	 <p>• Remove 4 screws (1~4).</p>

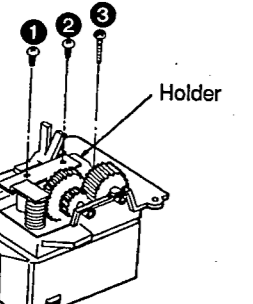
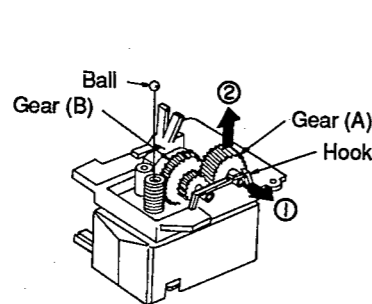
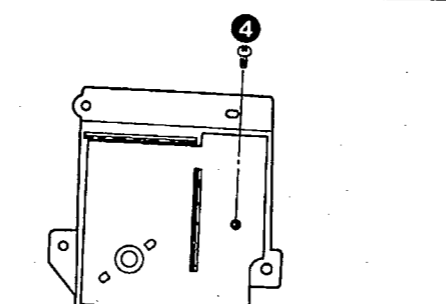
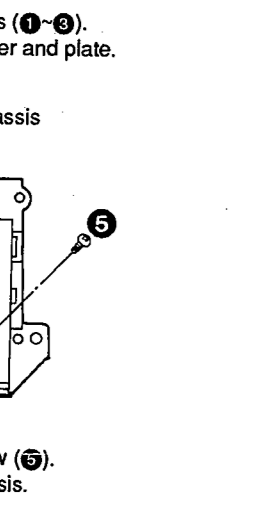
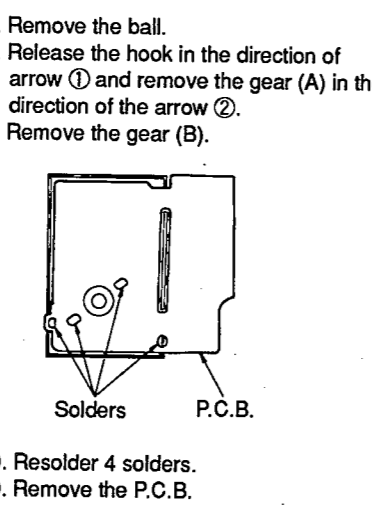
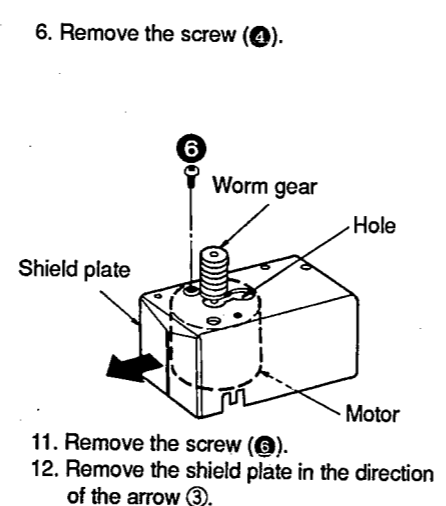
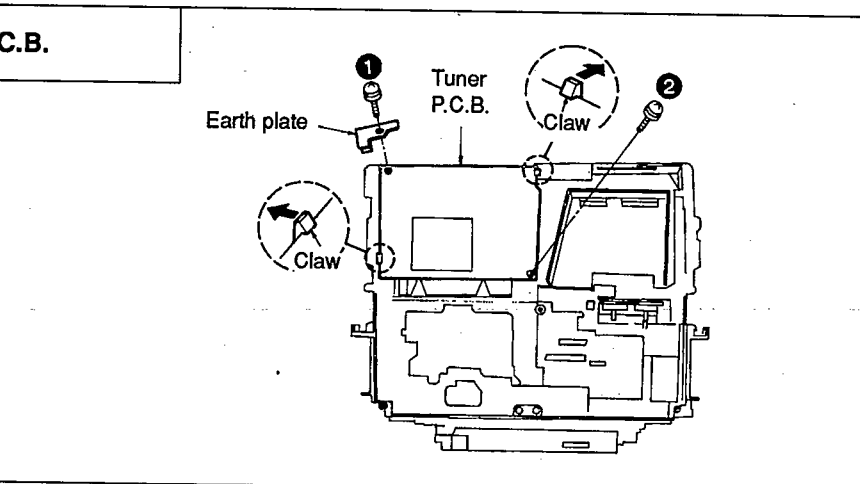
<p>Ref. No. 13</p>	<p>Disassemble of the Open/Close Unit</p>		
<p>Procedure 1→2→4→5→6→10→11→12→13</p>			
<p>1. Remove 3 screws (1~3). 2. Remove the holder and plate.</p>		<p>3. Remove the ball. 4. Release the hook in the direction of arrow ① and remove the gear (A) in the direction of the arrow ②. 5. Remove the gear (B).</p> 	<p>6. Remove the screw (4).</p> 
<p>7. Remove the screw (5). 8. Remove the chassis.</p>	<p>9. Resolder 4 solders. 10. Remove the P.C.B.</p>	<p>11. Remove the screw (6). 12. Remove the shield plate in the direction of the arrow ③.</p> 	

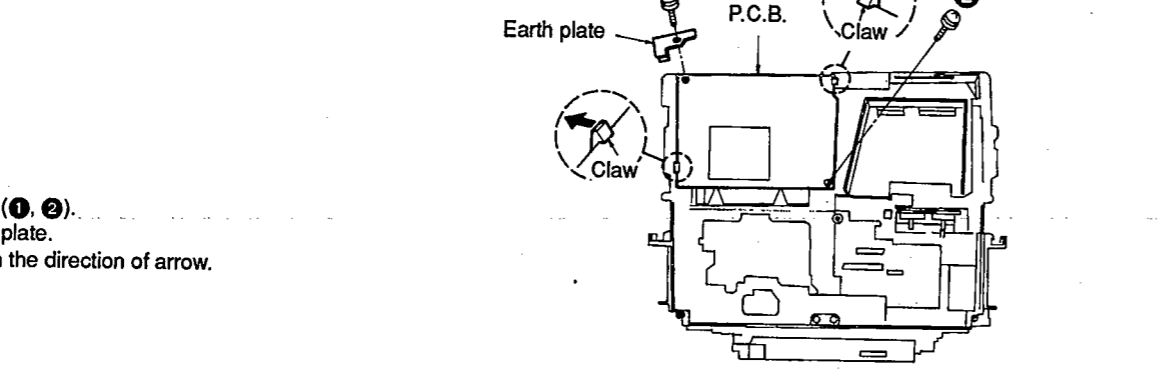
<p>Ref. No. 14</p>	<p>Removal of the Tuner P.C.B.</p>		
<p>Procedure 1→2→4→5→6→10→11→14</p>			
<p>1. Remove 2 screws (1, 2). 2. Remove the earth plate. 3. Release 2 claws in the direction of arrow.</p>			

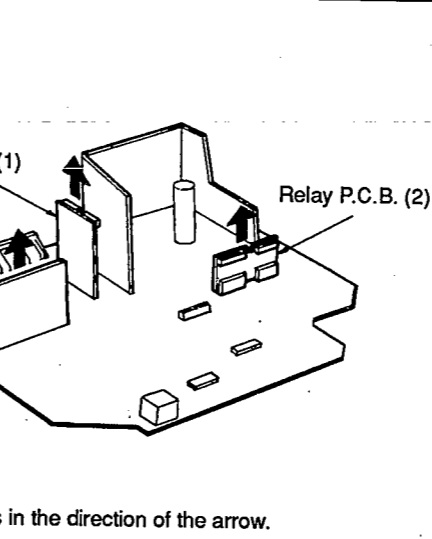
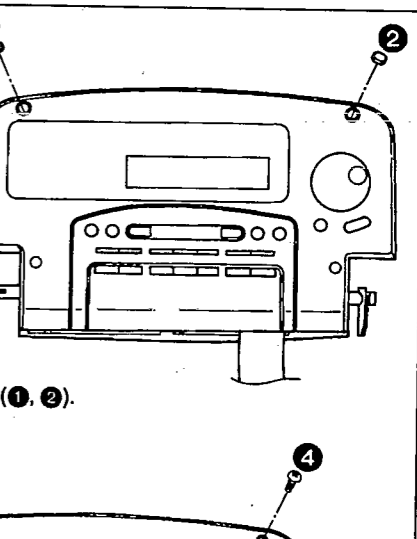
<p>Ref. No. 15</p>	<p>Removal of the ASP P.C.B. and Relay P.C.B.</p>		<p>Ref. No. 16</p>	<p>Removal of the Display Panel</p>	
<p>Procedure 1→2→4→7→8→9→15</p>	 <p>• Pull out 3 P.C.B.s in the direction of the arrow.</p>		<p>Procedure 1→2→5→6→10→16</p>		

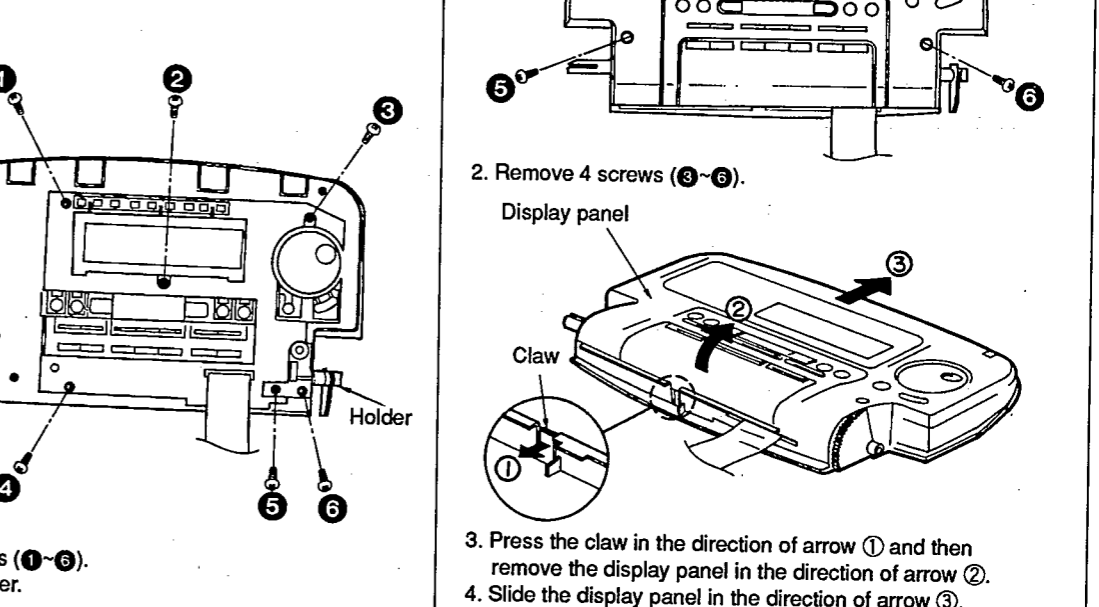
<p>Ref. No. 17</p>	<p>Removal of the LCD P.C.B.</p>				
<p>Procedure 1→2→5→6→10→16→17</p>					
<p>1. Remove 6 screws (1~6). 2. Remove the holder.</p>					

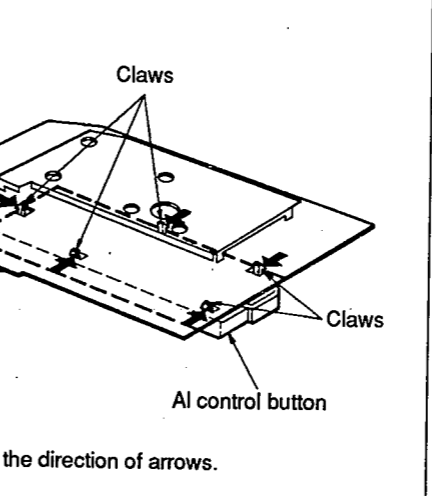
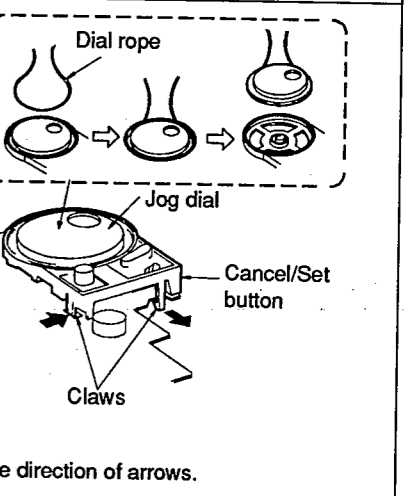
<p>Ref. No. 18</p>	<p>Removal of the AL Control Button</p>		<p>Ref. No. 19</p>	<p>Removal of the AI Jog Dial and Cancel/Set Button</p>	
<p>Procedure 1→2→5→6→10→16→17→18</p>	 <p>• Release 5 claws in the direction of arrows.</p>		<p>Procedure 1→2→5→6→10→16→17→18</p>		
<p>1. Remove the jog dial. 2. Release 2 claws in the direction of arrows.</p>					

Ref. No. 20 **Removal of the Disc Clamper**

Procedure
1→2→4
→7→20

• **Disassembly of the disc clamper**

1. Release 3 claws in the direction of arrows.
2. Disassemble the disc clamper as shown above.

• Remove 3 screws (1~3).

Ref. No. 21 **Removal of the Disc Tray**

Procedure
1→2→4
7→20→21

1. Slide the lever fully in the direction of arrow ①.
(The traverse unit goes down.)

2. Move the disc tray slightly in the direction of arrow ② and unfasten the claw and the rib.
3. Remove 2 screws (1, 2).

4. Lift the disc tray in the direction of arrow ③.
5. Unfasten the rib from the claw of the chassis.

6. Remove the screw (3).
7. Remove the slider and the shaft.

Ref. No. 22 **Removal of the CD P.C.B.**

Procedure
1→2→4
→7→22

• **Removal of the flexible cable**
Slide the top of the connector in the direction of the arrow ① and disconnect the flexible cable in the direction of the arrow ②.

1. Remove the 3 screws (1~3).
2. Unsolder the 2 terminals of spindle motor.
3. Unsolder the 2 terminals of traverse motor.

4. Remove the flexible cable (CN701).

Note:
Insert a short pin into the flexible cable for traverse unit.

Ref. No. 23 **Removal of the Loading Motor P.C.B. and Loading Motor**

Procedure
1→2→4→7
→20→21→23

1. Remove the belt.
2. Remove the 2 screws (1, 2).

3. Remove the screw (3).
4. Unsolder the 2 terminals of loading motor.

Ref. No. 24 **Removal of the Traverse Unit**

Procedure
1→2→4→7
→22→24

1. Widen 3 bosses by using a screwdriver and remove 3 pins.

2. Release the claw and then remove the traverse unit in the direction of arrow.

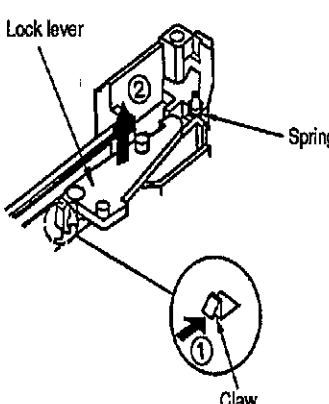
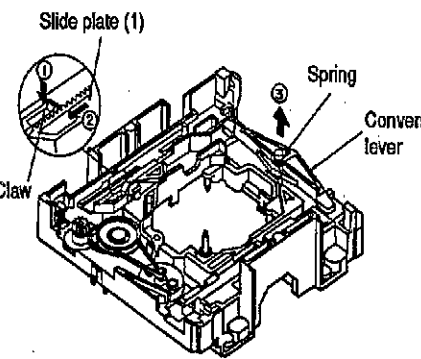
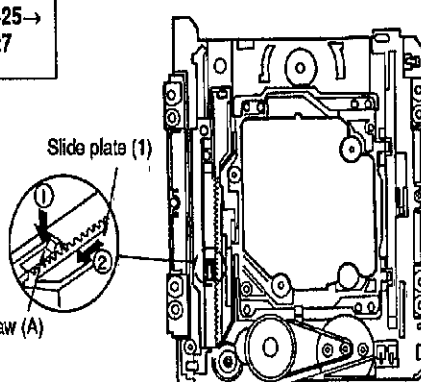
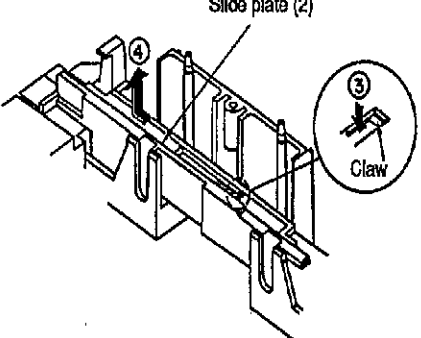
Ref. No. 25	Ref. No. 26
Removal of the Lock Lever Procedure 1→2→4→7→ 22→24→25	Removal of the Conversion Lever Procedure 1→2→4→7→ 22→24→25→26
 <p>1. Remove the spring. 2. Release the claw in the direction of the arrow ①, and then remove the lock lever in the direction of arrow ②.</p>	 <p>1. Remove the spring. 2. Push the claw in the direction of arrow ①, and then move the slide plate (1) in the direction of arrow ②. 3. Remove the conversion lever in the direction of arrow ③.</p>
Ref. No. 27	Ref. No. 28
Removal of the Traverse Chassis Procedure 1→2→4→7→ 22→24→25→ 26→27	Removal of the Slide Plate (1) and Slide Plate (2) Procedure 1→2→4→7→ 22→24→25→ 26→27→28
 <p>1. Push the claw (A) in the direction of arrow ①, and then move the slide plate (1) in the direction of arrow ②.</p>	 <p>1. Push the claw (A) in the direction of arrow ①, and then move the slide plate (1) in the direction of arrow ②.</p> <p>2. Push 2 claws (B) in the direction of arrow ③, and then remove the traverse chassis.</p> <p>■ Removal of the Slide Plate (1) ● Move the slide plate (1) in the direction of the arrow ①, and remove the slide plate (1) in the direction of the arrow ②.</p> <p>■ Removal of the Slide Plate (2) ● Push the claw in the direction of the arrow ③, and remove the slide plate (2) in the direction of the arrow ④.</p>

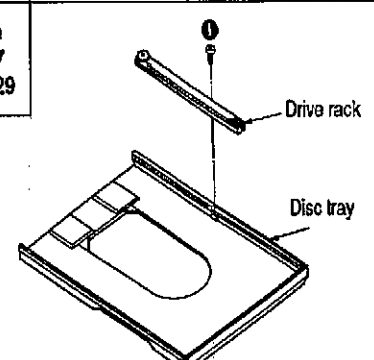
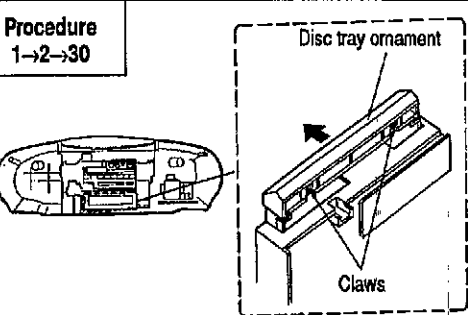
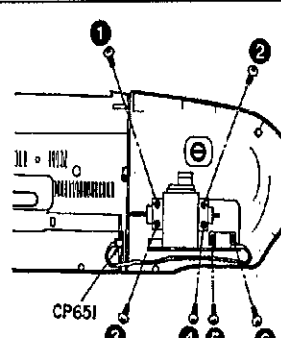
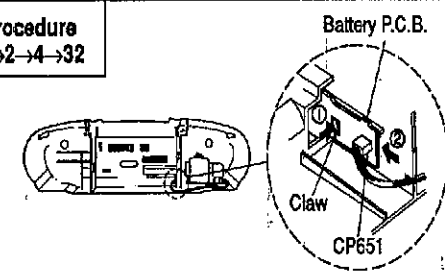
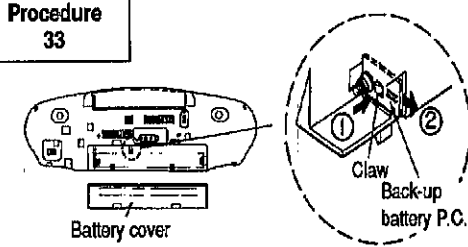
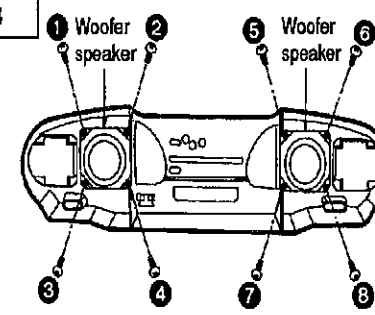
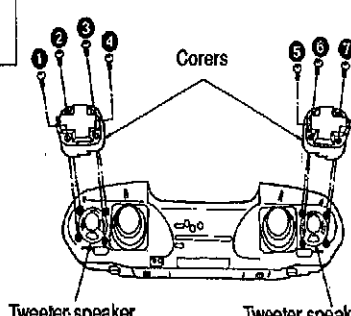
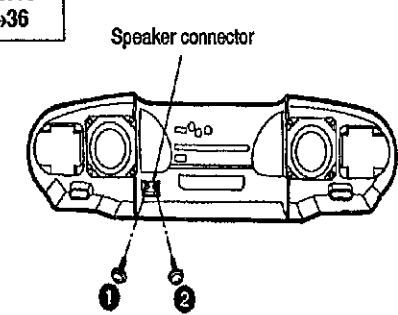
Ref. No. 29	Ref. No. 30
Removal of the Drive Rack Procedure 1→2→4→7 →20→21→29	Removal of the Disc Tray Ornament Procedure 1→2→30
 <p>● Remove the screw (①).</p>	 <p>● Remove the disc tray in the direction of arrow by keeping the 2 claws pressed.</p>
Ref. No. 31	Ref. No. 32
Removal of the Power P.C.B. Procedure 1→2→4→31	Removal of the Battery P.C.B. Procedure 1→2→4→32
 <p>1. Release the connector (CP651). 2. Remove 6 screws (①~⑥).</p>	 <p>1. Remove the connector (CP651). 2. Remove the battery P.C.B. in the direction of arrow ② by keeping the claw pressed in the direction of arrow ①.</p>
Ref. No. 33	Ref. No. 34
Removal of the Back-up Battery P.C.B. Procedure 33	Removal of the Woofer Speaker Procedure 1→2→34
 <p>1. Remove the battery cover. 2. Remove the back-up battery P.C.B. in the direction of arrow ② by keeping the claw pressed in the direction of arrow ①.</p>	 <p>● Remove 8 screws (①~⑧).</p>
Ref. No. 35	Ref. No. 36
Removal of the Tweeter Speaker Procedure 1→2→35	Removal of the Speaker Connector Procedure 1→2→36
 <p>1. Remove 8 screws (①~⑧). 2. Remove 2 covers.</p>	 <p>● Remove 2 screws (①, ②).</p>

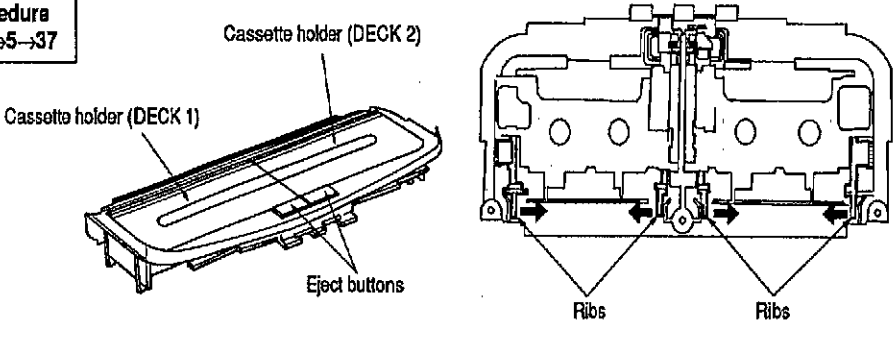
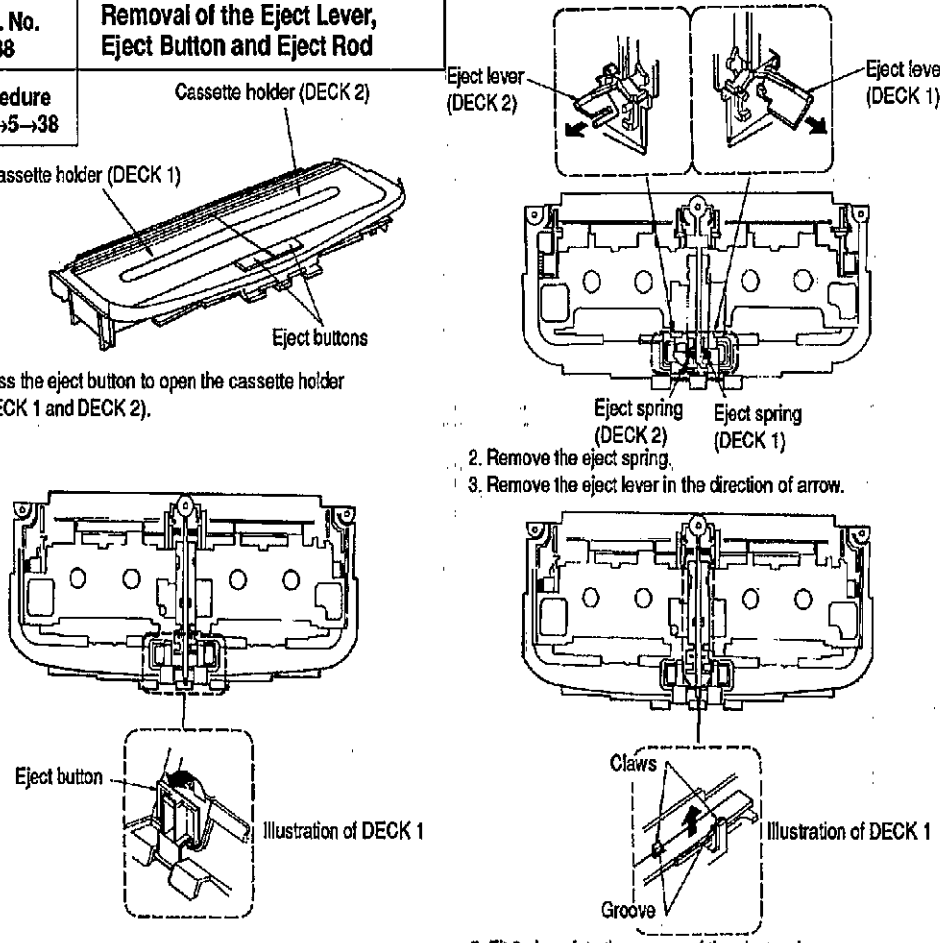
Ref. No. 37	Removal of the Cassette Holder		
Procedure 1→2→5→37	 <p>1. Press the eject button and then open the cassette holder</p> <p>2. Remove the cassette holder by keeping the 4 ribs pressed in the direction of arrow.</p>		
Ref. No. 38	Removal of the Eject Lever, Eject Button and Eject Rod		
Procedure 1→2→5→38	 <p>1. Press the eject button to open the cassette holder (DECK 1 and DECK 2).</p> <p>2. Remove the eject spring.</p> <p>3. Remove the eject lever in the direction of arrow.</p> <p>4. Remove the eject button in the direction of arrow.</p> <p>5. Fit 2 claws into the groove of the eject rod.</p> <p>6. Remove the eject rod in the direction of arrow.</p>		

NOTE:
Please refer to pages 10-13 in the service manual for Model No. SL-CH550 (Order No. AD9208264C8) for information on "INSTALLING SERVO (CD) P.C.B.", "INSTALLING OF GUIDE SHAFT", "CD UNIT ASSEMBLY", "INSTALLING DISC TRAY UNIT" and "INSTALLING DISC TRAY".

●INSTALLATION OF CASSETTE HOLDER

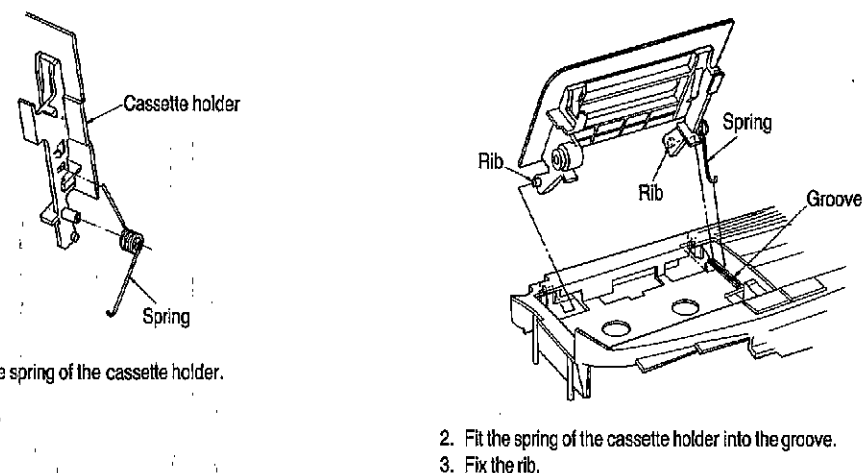

●INSTALLATION OF MECHANISM UNIT

●Install the mechanism unit by connecting the connectors correctly.

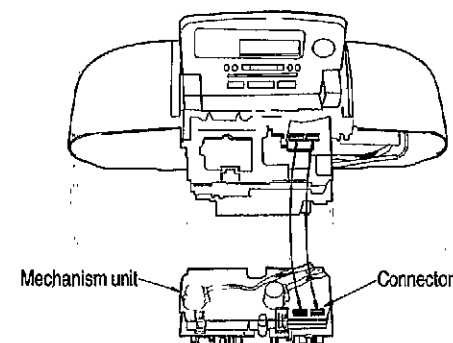

●INSTALLATION OF FRONT PANEL

●Install the front panel by connecting the speaker connector correctly.

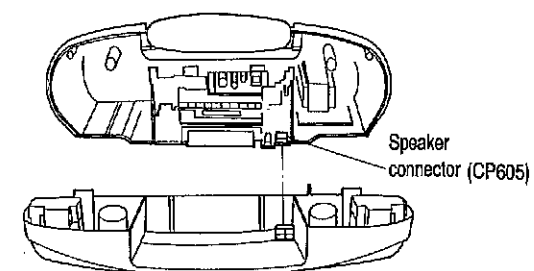

●MEASURE FOR TAPE TROUBLE

If a cassette tape cannot be removed from the deck since the tape is caught by the capstan or pinch roller during playback or recording, rotate the pulley in the direction of the arrow to remove the tape.

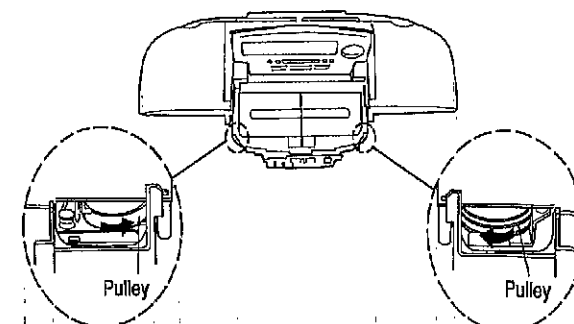

SCHEMATIC DIAGRAM • TUNER AND CD CIRCUIT (Parts list on pages 69~77.)

A TUNER CIRCUIT

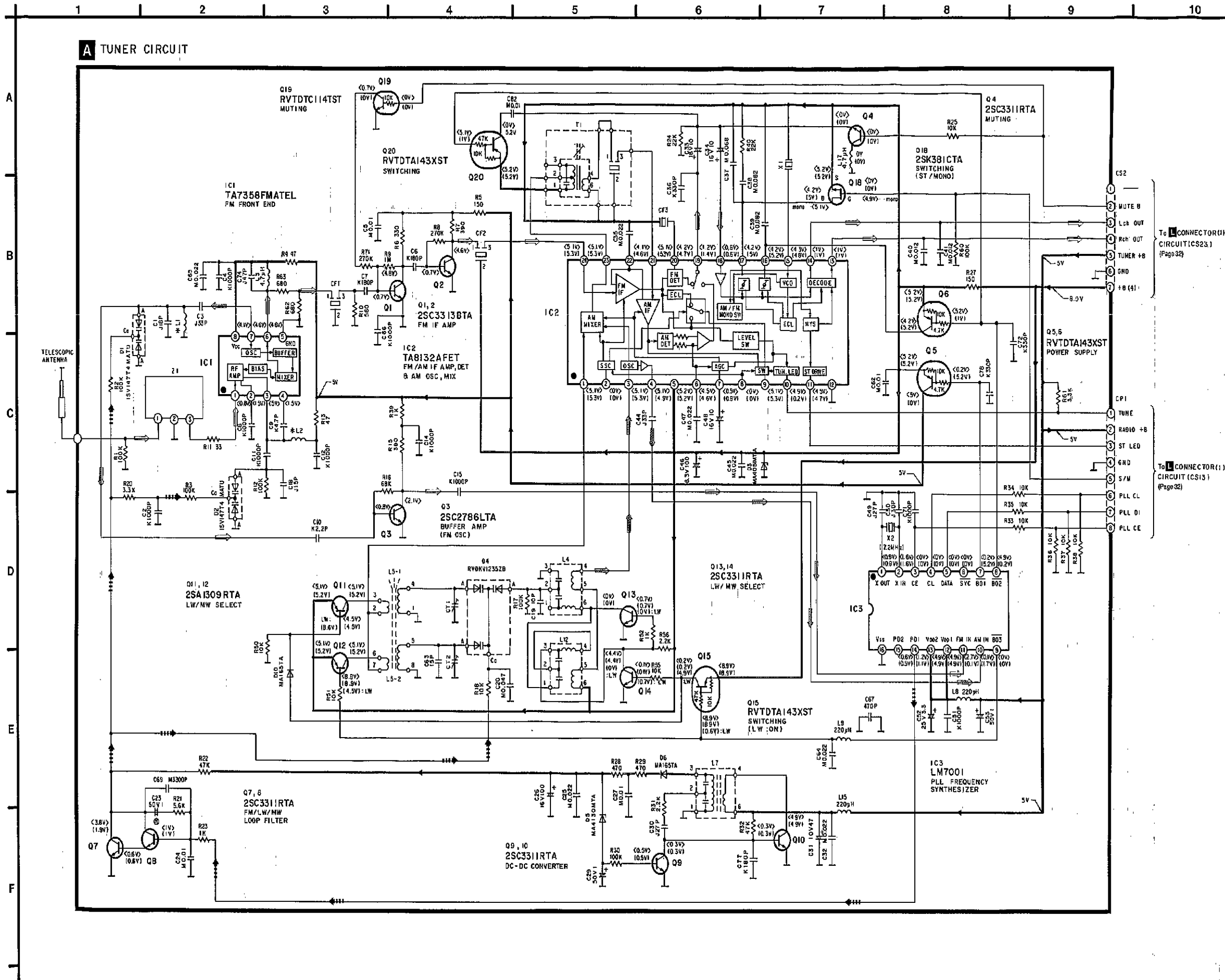

11

12

13

14

15

16

17

18

19

B CD CIRCUIT

OPTICAL PICK UP CIRCUIT

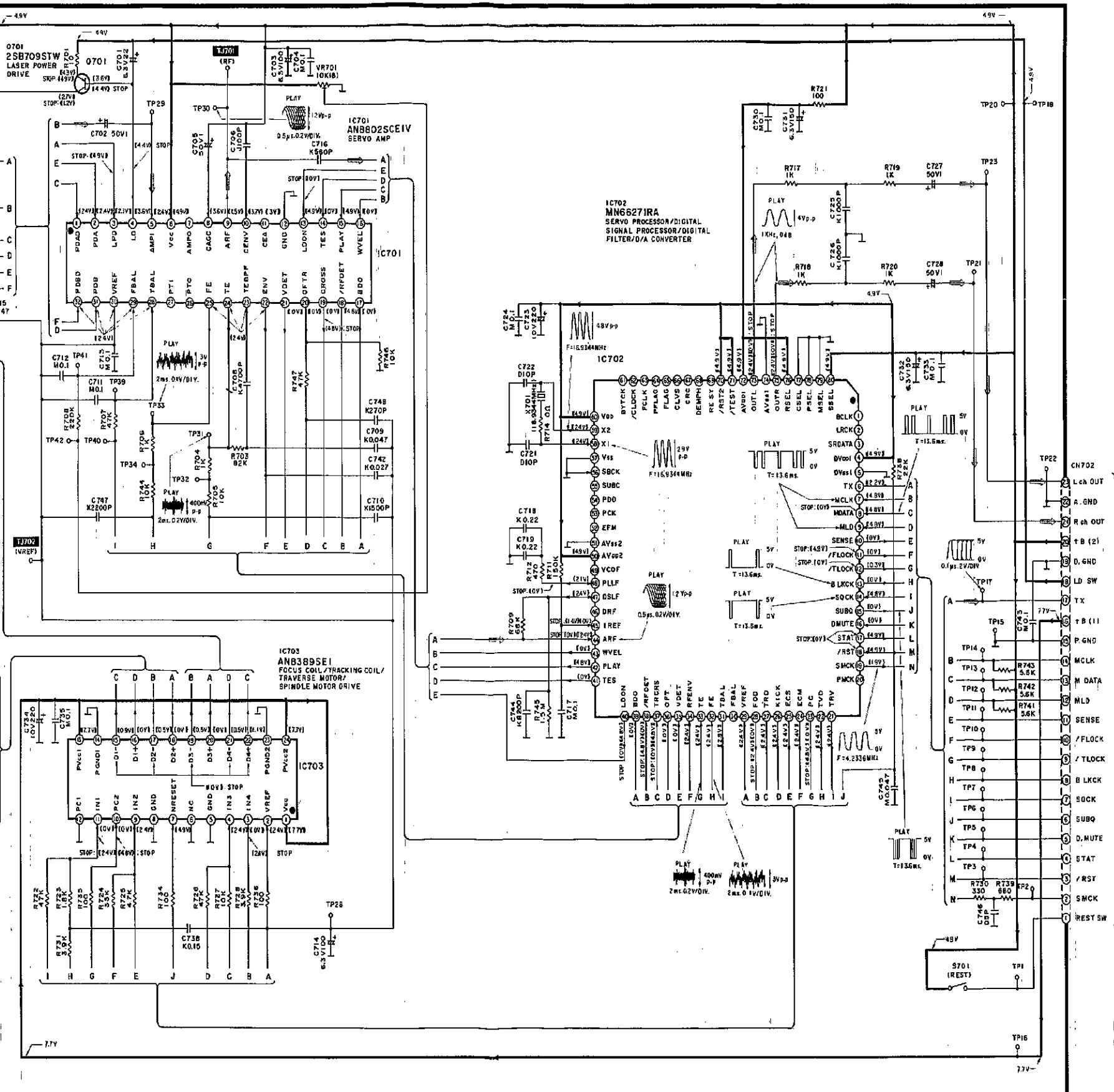
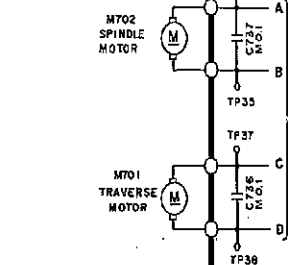
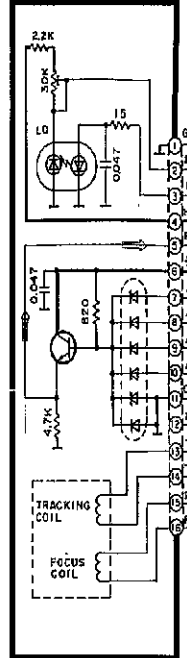

To MAIN CIRCUIT (CS702) (Page 38)

SCHEMATIC DIAGRAM • MAIN, CONNECTOR, PANEL OPEN/CLOSE, ASP, LOADING MOTOR

Notes:

<for Main circuit>

- S650 : AC/DC select switch.
- S681 : Disc tray open/close switch (CD OPEN/CLOSE)
- S682 : Top panel open/close switch. (OPEN/CLOSE)
- S683 : Volume up switch. (VOL +)
- S684 : Volume down switch. (VOL -)
- S685 : Operation switch. (OPERATION)
- S686 : CD stop switch. (■)
- S687 : CD playback switch. (▶)
- S688 : Function select switch. (TUNER/BAND)
- S689 : Deck forward side playback switch. (▶)
- S690 : Deck reverse side playback switch. (◀)
- S691 : Deck stop switch. (■)
- S692 : Deck fast/TPS switch. (TPS▶▶)
- S693 : Deck fast/TPS switch. (◀◀TPS)
- S790 : Disc tray close detect switch.
- S791 : Disc tray open detect switch.
- S4601 : Top panel open detect switch.
- S4602 : Top panel close detect switch.

<LCD circuit>

- S800 : AI jog dial. (AI JOG)
- S801 : Program set switch. (SET)
- S802 : Cancel switch. (CANCEL)
- S803 : Timer/clock switch. (TIMER/CLOCK)
- S804 : Sleep switch. (SLEEP)
- S805 : Timer recording switch. (REC-TIMER)
- S806 : Timer play switch. (PLAY-TIMER)
- S807 : ATLS switch. (ATLS)
- S808 : Recording pause switch. (●■)
- S809 : Auxiliary input select switch. (AUX)
- S810 : Tape counter reset switch. (COUNTER RESET)
- S811 : Reverse mode select switch. (REV MODE)
- S812 : Deck select switch. (DECK1/2)
- S813 : Edit recording switch. (HIGH)
- S814 : Edit recording switch. (NORMAL)
- S815 : T-SURROUND switch. (T-SURROUND)
- S816 : Beep on/off switch. (BEEP)
- S817 : CD edit switch. (CD EDIT)
- S818 : Dolby NR switch. (DOLBY NR)
- S819 : Preset equalizer select switch. (PRESET EQ)
- S823 : S-XBS level control switch. (S-XBS LEVEL)
- S824 : Tuning mode select switch. (TUNING MODE)
- S825 : Title switch. (TITLE)

General

- DC voltage measurements are taken with electronics voltmeter.
- The negative terminal of the battery provides negative meter connection point.

No mark...TAPE PLAYBACK (DECK 2) F...TUNER (())...CD

[]...AUX

•Battery current:

Vol. min	420 mA (FM)	Vol. max	1010 mA (FM)
	410 mA (LW/MW)		690 mA (LW/MW)
	490 mA (TAPE)		1800 mA (TAPE)
	620 mA (CD)		2140 mA (CD)

Measurement instruction
 LW/MW: 74 dB/m, 30% Mod.
 FM: 60 dB, 30% Mod.
 TAPE: 315 Hz, 0 dB
 CD: 1 kHz, 0 dB

•Important safety notice.

- Components identified by Δ mark have special characteristics important for safety.
- When replacing any of these components, use only manufacturer's specified parts.

•This schematic diagram may be modified at any time with the development of new technology.

 : FM Signal Line

 : CD Signal Line

 : AF Signal Line

 : Recording Signal Line

 : Mic Signal Line

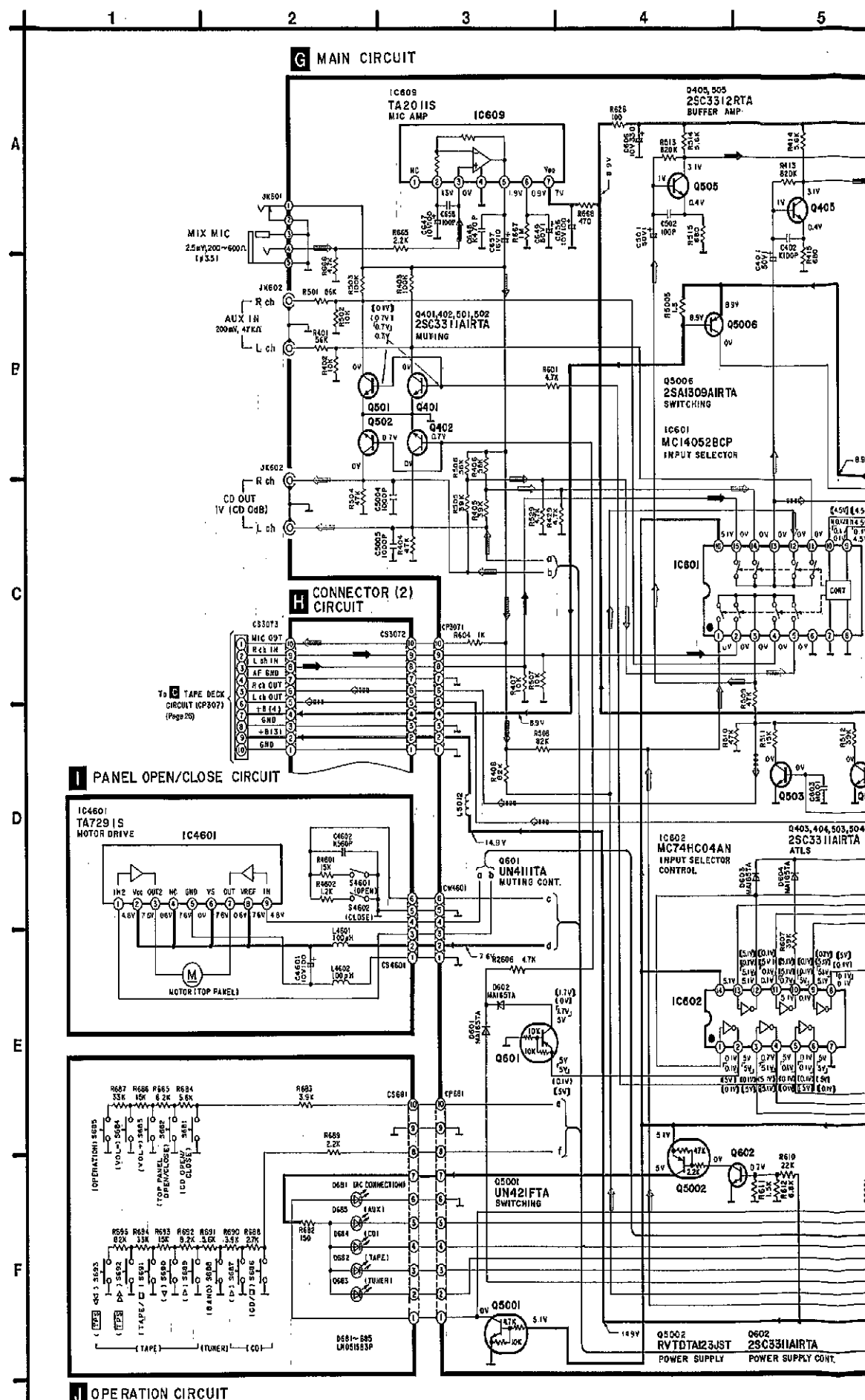
 : +B Line

F LCD CIRCUIT

